



TRI-MAG, Inc.
your POWER Specialists

1601 N. CLANCY CT. • VISALIA, CA 93291
 (559) 651-2222 • FAX (559) 651-0188
<http://www.tri-mag.com>
sales@tri-mag.com

DT100Z SERIES

120 Watts with PFC

UNIVERSAL INPUT



DESCRIPTION

DT100Z series is a 120 watts, single output, external desktop power for the application of general purpose. It is designed by using active power factor correction and in full compliance with EN 61000-3-2 regulations and EMI CISPR22 level "B". The efficiency can reach up to 85%.

FEATURES

- EMI FCC Class B
- Power Factor Correction
- No Minimum Load Required
- Single Output
- Universal input 90VAC to 260VAC

APPLICATIONS

- Computer Peripherals
- Telecommunications
- Tape Drives
- Test Instrumentation Product
- Data Acquisition

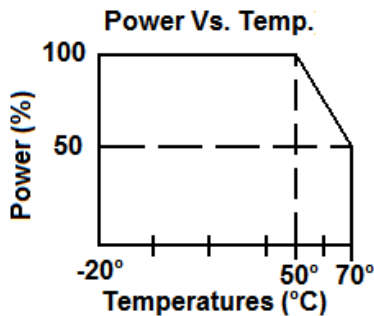

GENERAL SPECIFICATIONS

Input Voltage.....	90VAC to 264VAC
Input Frequency.....	47Hz to 63Hz
Inrush Current (cold).....	Less than 50A at 220VAC, 25°C
Operating Temperature.....	0 to 40°C
Storage Temperature.....	-20°C to 85°C
Cooling.....	Free Air Convection
Efficiency.....	85% Typical
Holdup Time.....	>16ms at 115VAC
Oversvoltage Type.....	Latchoff
Overload Protection.....	Foldback Within 150% rated load
Designed in full compliance with.....	UL 60950-1 CSA 22.2 #60950-1 EN60950-1
EMI.....	cispr22 "B" FCC docket class "B"
Harmonics.....	EN61000-3-2 Class "D"
EMS.....	EN61000-4-2,-3,-4,-5,-6,-11

MECHANICAL SPECIFICATIONS

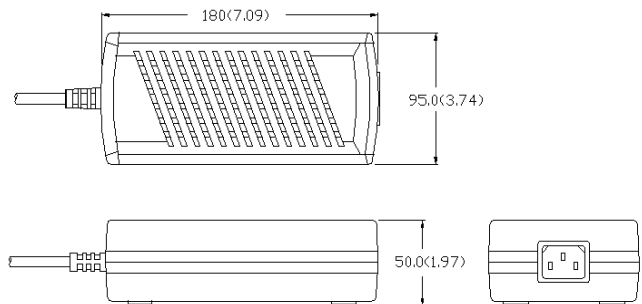

OUTPUT CONNECTOR:

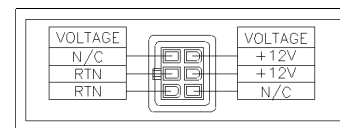

NOTE: OTHER CONNECTORS AVAILABLE UPON REQUEST.
 CABLE LENGTH TYP. 6.0'.



TRI-MAG, Inc.
® *your* POWER Specialists

1601 N. CLANCY CT. • VISALIA, CA 93291
(559) 651-2222 • FAX (559) 651-0188
<http://www.tri-mag.com>
sales@tri-mag.com

OUTPUT SPECIFICATIONS

Model	Watts	Voltage (Vdc)	Load (A)			Tolerance ±	Ripple & Noise	Regulation	
			Min.	Rate	Peak			Line	Load
DT100Z-5	120	+12V	0	9	15	5%	120 mV	±1%	±3%
DT100Z-8	120	+15V	0	7.5	10	5%	150 mV	±1%	±3%
DT100Z-6	120	+24V	0	5	7	5%	200 mV	±1%	±3%
DT100Z-14	120	+48V	0	2.5	4	5%	200 mV	±1%	±3%
DT100Z-3	120	+18V	0	6.5	9	5%	100 mV	±1%	±3%

Note: Contact factory for Safety Agency Approved status.

1. Each output can provide up to peak load temporarily. Continuous staying in more than rated load is not allowed.
2. At factory, in 60% rated load condition, each output is checked to be within voltage accuracy.
3. Line regulation is defined by changing ±10% of input voltage from nominal line at rated load.
4. Load regulation is defined by changing ±40% of measured output load from 60% rated load.
5. The ripple and noise is measured by using 15MHz bandwidth limited oscilloscope and terminated each output with a 0.47 µF capacitor at rated load and nominal line.
6. Hold up time is measured from the end of the last charging pulse to the time which the main output drops down to 95% output voltage at rated load and nominal line.
7. Efficiency is measured at rated load.