

**A****AMBIENT TEMPERATURE**

The still-air temperature in the immediate vicinity of a power supply, measured a minimum of 4 inches (100 mm) from the supply.

AMP-REG (trademark)

A control technique which gives a power supply a constant current characteristic above the rated output current. This permits direct paralleling of two or more supplies for increased total output current.

APPARENT POWER

A value of power for AC circuits that is calculated as the product of RMS current times RMS voltage, without taking the power factor into account.

B**BALUN**

A transformer which presents a high impedance to common-mode signals and a low impedance to differential-mode signals. It is commonly used on the input of switching power supplies to suppress common-mode noise. [See Figure 1.](#)

BANDWIDTH

A range of frequencies over which a certain phenomenon is to be considered.

BODE PLOT

A graphic plot of gain versus frequency for a control loop, typically used to verify control loop stability, including phase margin.

BREAKDOWN VOLTAGE

The maximum AC or DC voltage which may be applied from input to output and/or chassis of a power supply. [See Figure 2.](#)

BRIDGE RECTIFIER

A full wave rectifier circuit employing four rectifiers in a bridge configuration.

BROWNOUT

Condition during peak usage periods when electric utilities reduce their nominal line voltage 10% to 15%.

BURN-IN

Operating a newly manufactured power supply, usually at rated load, for a period of time in order to force component infant mortality failures or other latent defects before the unit is delivered to a customer.

C**CAPACITIVE COUPLING**

Coupling of a signal between two circuits, due to discrete or parasitic capacitance between the circuits.

CENTER TAP

An electrical connection made at the centre of a transformer or inductor winding, usually so as to result in an equal number of turns on either side of the tap.

COMMON-MODE NOISE

The component of noise which is common to both the DC output and return lines with respect to input ground.

COMPLIANCE VOLTAGE

The output voltage of a constant current power supply.

CONSTANT CURRENT LIMITING CIRCUIT

Current-limiting circuit that holds output current at some maximum value whenever an overload of any magnitude is experienced.

CONSTANT CURRENT POWER SUPPLY

A power supply that regulates its output current, within specified limits, against changes in line, load, ambient temperature, and time.

CONSTANT VOLTAGE POWER SUPPLY

A power supply designed to regulate the output voltage for changes in line, load, ambient temperature, and drift resulting from time.

CREST FACTOR

In an AC circuit, Crest Factor is the mathematical ratio of the peak to RMS values of a waveform. Crest factor is sometimes used for describing the current stress in AC mains supply wires, since for a given amount of power transferred, the RMS value, and hence the losses, become greater with increasing peak values. Crest Factor gives essentially the same information as Power Factor, and is being replaced by Power Factor in power supply technology.

CROSS REGULATION

In a multiple output power supply, the percent voltage change at one output caused by the load change on another output.

CROWBAR

An overvoltage protection circuit which rapidly places a low resistance shunt across the power supply output terminals if a predetermined voltage is exceeded. [See Figure 3.](#)

CSA

Canadian Standards Association. An independent Canadian organization concerned with testing for public safety.

CURRENT LIMITING

See Output Current Limiting.

CURRENT LIMITING CIRCUIT

A bounding circuit designed to prevent overload of a constant-voltage power supply. It can take the form of constant, foldback or cycle-by-cycle current limiting.

D

DERATING

The specified reduction in an operating parameter to improve reliability. Generally for power supplies, it is the reduction in output power at elevated temperatures. [See Figure 4.](#)

DIFFERENTIAL MODE NOISE

The component of noise measured between the DC output and output return. See Ripple and Noise.

DRIFT

The change in output voltage of a power supply over a specified period of time, following a warm-up period, with all other operating parameters such as line, load, and ambient temperature held constant.

DYNAMIC LOAD REGULATION

See Output Impedance.

E

EFFICIENCY

The ratio of output power to input power. It is generally measured at full-load and nominal line conditions. In multiple output switching power supplies, efficiency can be a function of total output power and its division among the outputs.

ELECTROMAGNETIC INTERFERENCE (EMI)

Also called radio-frequency interference (RFI), EMI is unwanted high frequency energy caused by the switching transistors, output rectifiers, and zener diodes in switching power supplies. EMI can be conducted through the input or output lines or radiated through space.

ESR

Equivalent Series Resistance. The amount of resistance in series with an ideal capacitor which exactly duplicates the performance of a real capacitor. In high frequency applications low ESR is very important.

F



FILTER

A frequency-sensitive network that attenuates unwanted noise and ripple components of a rectified output.

FLOATING OUTPUT

An output of a power supply that is not connected or referenced to any other output, usually denotes full galvanic isolation. They generally can be used as either positive or negative outputs. Non-floating outputs share a common return line, and are hence DC referenced to one another.

FLYBACK CONVERTER

The flyback converter is the simplest type of switcher. In most cases, it uses one switch and only needs one magnetic element - the transformer. Flybacks are limited to outputs of generally lower than 200 Watts.

FOLDBACK CURRENT LIMITING CIRCUIT

Current limiting circuit that gradually decreases the output current under overload conditions until some minimum current level is reached under a direct short circuit. [See Figure 7.](#)

FORWARD CONVERTER

Similar to flyback converter but the forward converter stores energy in the output inductor instead of the transformer.

G

GROUND

An electrical connection to earth or some other conductor that is connected to earth. Sometimes the term "ground" is used in place of "common," but such usage is not correct unless the connection is also connected to earth.

GROUND LOOP

An unwanted feedback condition caused by two or more circuits sharing a common electrical ground line.

H

HALF BRIDGE CONVERTER

A power switching circuit similar to the full bridge converter except that only two transistors are used, with the other two replaced by capacitors.

HEATSINK

Device used to conduct away and disperse the heat generated by electronic components.

HI-POT TEST

High Potential Test. A test to determine if the breakdown voltage of a transformer or power supply exceeds the minimum requirement. It is performed by applying a high voltage between the two isolated test points.

HOLDOVER TIME

See Hold-Up Time.

HOLD-UP TIME

The time during which a power supplies output voltage remains within specification following the loss of input power.

HYBRID TECHNOLOGY

The use of ceramic based substrates to support and interconnect components in power supplies. Resistors and interconnections are screen printed on the substrate using various inks. These are then fixed (fired) in place by a high temperature process.

I

INHIBIT

The ability to electrically turn off the output of a power supply from a remote location.

INPUT LINE FILTER

A low-pass or band-reject filter at the input of a power supply which reduces line noise fed to the supply. This filter may be external to the power supply.



TRI-MAG, Inc.

1601 N. CLANCY CT.
VISALIA, CA. 93291
PH: (559)651-2222

sales@tri-mag.com
http://www.tri-mag.com
FAX: (559)651-0188

TITLE: SMPS GLOSSARY

APPLICATION NOTE
TMI-AN 08-005 Rev. A

INPUT PI FILTER

See Pi Filter.

INPUT VOLTAGE RANGE

The high and low input voltage limits within which a power supply or DC/DC converter meets its specifications.

INRUSH CURRENT

The peak instantaneous input current drawn by a power supply at turn-on.

INRUSH CURRENT LIMITING

A circuit which limits the inrush current during turn-on of a power supply.

INVERTER

A power converter which changes DC input power into AC output power.

ISOLATION

The electrical separation between input and output of a power supply by means of the power transformer. The isolation resistance (normally in megaohms) and the isolation capacitance (normally in picofarads) are generally specified and are a function of materials and spacings employed throughout the power supply. [See Figure 2.](#)

ISOLATION VOLTAGE

The maximum AC or DC voltage which may be applied for a short, defined duration from input to output and/or chassis of a power supply.

J

No terms listed.

K

No terms listed.

L

LEAKAGE CURRENT

Current flowing between the output buses and chassis ground due to imperfections in electronic components and designs. It must be tightly controlled to satisfy safety regulations such as UL and VDE.

LINE FREQUENCY REGULATION

The variation of an output voltage caused by a change in line input frequency, with all other factors held constant. This effect is negligible in switching and linear power supplies, but it is a critical specification of ferroresonant power supplies.

LINE REGULATION

The variation of an output voltage due to a change in the input voltage, with all other factors held constant. Line regulation is expressed as the maximum percentage change in output voltage as the input voltage is varied over its specified range.

LINEAR REGULATOR

A common voltage-stabilization technique in which the control device (usually a transistor) is placed in series or parallel with the power source to regulate the voltage across the load. The term 'linear' is used because the voltage drop across the control device is varied continuously to dissipate unused power.

LOAD REGULATION

Variation of the output voltage due to a change in the outputs load from no load to full load, with all other factors held constant. It is expressed as a percent of the nominal DC output voltage.

LOCAL SENSING

Using the voltage output terminals of the power supply as sense points for voltage regulation.



TRI-MAG, Inc.

1601 N. CLANCY CT.
VISALIA, CA. 93291
PH: (559)651-2222

sales@tri-mag.com
http://www.tri-mag.com
FAX: (559)651-0188

TITLE: SMPS GLOSSARY

APPLICATION NOTE
TMI-AN 08-005 Rev. A

LOGIC ENABLE

The ability to turn a power supply on and off with a TTL signal. A logic low generally turns the supply off; a logic high turns it on.

M

MAGNETIC AMPLIFIER

A magnetic device used to improve the cross regulation of multiple output AC/DC converters.

MARGINING

Adjusting a power supply output voltage up or down from its minimal setting in order to verify system performance margin with respect to supply voltage. This is usually done electrically by a system-generated control signal.

MINIMUM LOAD

The minimum load current/power that must be drawn from the power supply in order for the supply to meet its performance specifications. Less frequently, a minimum load is required to prevent the power from failing.

MODULAR

A physically descriptive term used to describe a power supply made up of a number of separate subsections, such as an input module, power module, or filter module. Modular construction tends to lower the MTBF.

MOSFET

Metal Oxide Semiconductor Field Effect Transistor. The device of choice for the main switch in switched mode power supplies having much better switching characteristics than Bipolar Transistors.

MTBF

Mean Time between Failure. The failure rate of a power supply, expressed in hours, established by the actual operation or calculation from a known standard such as MIL-HDBK-217.

N

NOISE

Noise is the aperiodic, random component of undesired deviations in output voltage. Usually specified in combination with ripple. See PARD and Ripple.

NOMINAL VALUE

The stated or objective value for a quantity, such as output voltage, which may not be the actual value measured.

O

OFF-LINE POWER SUPPLY

A power supply which operates off the AC line directly, without using a power transformer prior to rectification and filtering.

OPEN FRAME

A power supply where there is no external metal chassis; the power supply is provided to the end user essentially as a printed circuit board which provides mechanical support as well as supporting the components and making electrical connections.

OPERATING TEMPERATURE RANGE

See Temperature Range, Operating.

OPERATIONAL POWER SUPPLY

A power supply with a high open loop gain regulator which acts like an operational amplifier and can be programmed with passive components.

OUTPUT CURRENT LIMITING

An output protection feature which limits the output current to a predetermined value in order to prevent damage to the power supply or the load under overload conditions. The supply is automatically restored to normal operation following removal of the overload. [See Figure 7.](#)

OUTPUT GOOD

A power supply status signal which indicates that the output voltage is within a certain tolerance. An output that is either too high or too low will deactivate the Output Good signal.

OUTPUT IMPEDANCE

The ratio of change in output voltage to change in load current.

OUTPUT NOISE

The AC component that may be present on the DC output of a power supply. Switch-mode power supply output noise has two components: a lower frequency component at the switching frequency of the converter and a high frequency component due to fast edges of the converter switching transitions. Noise should always be measured directly at the output terminals with a scope probe having an extremely short grounding lead.

OUTPUT VOLTAGE

The nominal value of the DC voltage at the output terminals of a power supply.

OUTPUT VOLTAGE ACCURACY

For a fixed output supply, the tolerance in percent of the output voltage with respect to its nominal value under all minimum or maximum conditions.

OVERLOAD PROTECTION

An output protection feature which limits the output current of a power supply under overload conditions so that it will not be damaged.

OVERSHOOT

A transient change in output voltage, in excess of specified output accuracy limits, which can occur when a power supply is turned on or off, or when there is a step change in line or load. [See Figure 8.](#)

OVERVOLTAGE CROWBAR

See Crowbar.

OVERVOLTAGE PROTECTION

A power supply feature which shuts down the supply, or crowbars or clamps the output, when its voltage exceeds a preset level.

P

PARALLEL OPERATION

The connection of the outputs of two or more power supplies of the same output voltage to obtain a higher output current than from either supply alone. This requires power supplies specifically designed to share the load.

PAR

Periodic and Random Deviation. A term used for the sum of all ripple and noise components measured over a specified bandwidth and stated in either peak-to-peak or RMS values. [See Figure 9.](#)

PEAK POWER

The absolute maximum output power that a power supply can produce without immediate damage. Peak power capability is typically well beyond the continuous reliable output power capability and should only be used infrequently.

P.F.C. POWER FACTOR CORRECTION

Standard AC/DC converters draw line current in pulses around the peaks in line voltage. This may be undesirable for several reasons. PFC circuits ensure that the line current is drawn sinusoidally and in phase with the sinusoidal line voltage.

PI FILTER

A commonly used filter at the input of a switching supply or DC/DC converter to reduce reflected ripple current. The filter usually consists of two parallel capacitors and a series inductance and is generally built into the supply. [See Figure 10.](#)

POWER FACTOR

The ratio of true power to apparent power in an AC circuit. In power conversion technology, power factor is used in conjunction with describing the AC input current to the power supply.

POWER FAIL DETECTION

A power supply option which monitors the input voltage and provides an isolated logic output signal when there is loss of line voltage.



TRI-MAG, Inc.

1601 N. CLANCY CT.
VISALIA, CA. 93291
PH: (559)651-2222

sales@tri-mag.com
http://www.tri-mag.com
FAX: (559)651-0188

TITLE: SMPS GLOSSARY

APPLICATION NOTE
TMI-AN 08-005 Rev. A

POST REGULATION

A linear regulator used on the output of a switching power supply to improve line and load regulation and reduce output ripple voltage.

POWER FOLDBACK

A power supply feature whereby the input power is reduced to a low value under output overload conditions.

PRE-REGULATION

The regulation at the front-end of a power supply, generally by a type of switching regulator; this is followed by output regulation, usually by a linear type regulator.

PRIMARY

The input section of an isolated power supply that is connected to the AC mains and hence has dangerous voltage levels present.

PROGRAMMABLE POWER SUPPLY

A power supply with an output controlled by an external resistor, voltage, or digital code.

PULSE-WIDTH MODULATION

A method of voltage regulation used in switching supplies whereby the output is controlled by varying the width, but not the height, of a train of pulses which drive a power switch.

PUSH-PULL CONVERTER

A power switching circuit which uses a center-tapped transformer and two power switches which are driven on and off alternatively. This circuit does not provide regulation by itself.

Q

No terms listed.

R

RATED OUTPUT CURRENT

The maximum load current which a power supply was designed to provide at a specified ambient temperature.

REFERENCE

The stable voltage, generally a Zener diode, from which the output voltage of a regulated supply is controlled.

REFLECTED RIPPLE CURRENT

The AC current generated at the input of a power supply or DC/DC converter by the switching operation of the converter, stated as peak-to-peak or RMS. [See Figure 11.](#)

REGULATION

The ability of a power supply to maintain an output voltage within a specified tolerance as referenced to changing conditions of input voltage and/or load.

REMOTE INHIBIT

A power supply interface signal, usually TTL compatible, which commands the power supply to shut down one or all outputs.

REMOTE SENSING

A technique of regulating the output voltage of a power supply at the load by means of sensing leads which go from the load back to the regulator. This compensates for voltage drops in the load leads. [See Figure 12.](#)

RESOLUTION

For an adjustable supply, the smallest change in output voltage that can be realized by the adjustment.

RESONANT CONVERTERS

A class of power converter topologies which reduce the level of switching losses by forcing either zero voltage across, or zero current through the switching device when it is turned on or off.

RETURN

The name for the common terminal of the output of a power supply; it carries the return current for the outputs.



REVERSE VOLTAGE PROTECTION

A feature which protects a power supply against a reverse voltage applied at the input or output terminals.

RFI

An abbreviation for Radio Frequency Interference, which is undesirable noise produced by a power supply or other electrical or electronic device during its operation. In power supply technology, RFI is usually taken to mean the same thing

RIPPLE AND NOISE

The magnitude of AC voltage on the output of a power supply, expressed in millivolts peak-to-peak or RMS, at a specified band width. This is the result of feed through of the rectified line frequency, internal switching transients and other random noise. [See Figure 9.](#)

S

SAFETY GROUND

A conductive path to earth that is designed to protect persons from electrical shock by shunting away any dangerous currents that might occur due to malfunction or accident.

SECONDARY

The output section of an isolated power supply which is isolated from the AC mains and specially designed for safety of personnel who might be working with power on the system.

SELV

An abbreviation for Safety Extra Low Voltage, a term generally defined by the regulatory agencies as the highest voltage that can be contacted by a person and not cause injury. It is often specifically defined as 30 VAC or 42.4 VDC.

SOFT START

A technique for gradually activating a power supply circuit when the power supply is first turned on. This technique is generally used to provide a gradual rise in output voltages and inrush current limiting.

SWITCHING FREQUENCY

The rate at which the DC voltage is switched on and off during the pulse width modulation process in a switching power supply.

T

TEMPERATURE COEFFICIENT

The average percent change in output voltage per degree centigrade change in ambient temperature over a specified temperature range.

TEMPERATURE DERATING

Reducing the output power of a power supply with increasing temperature to maintain reliable operation.

TEMPERATURE RANGE, OPERATING

The range of ambient or case temperatures within which a power supply may be safely operated and meet its specifications.

THERMAL PROTECTION

An internal safeguard circuit in a power supply which shuts down the unit in the event of excess internal temperature.

TOPOLOGY

The design type of a converter, indicative of the configuration of switching transistors, utilisation of the transformer, and type of filtering. Examples of topologies are the Flyback, Forward, Half-Bridge, Full Bridge, and Resonant.

TRACKING

A characteristic of a dual or other multiple output power supply whereby one or more outputs follow another output with changes in line, load and temperature, so that each maintains the same proportional output voltage, within specified tracking tolerance, with respect to common.

TRANSIENT RECOVERY TIME

The time required for the output voltage of a power supply to settle within specified output accuracy limits following a step change in output load current or a step change in input voltage. [See Figure 8.](#)



TRI-MAG, Inc.

1601 N. CLANCY CT.
VISALIA, CA. 93291
PH: (559)651-2222

sales@tri-mag.com
http://www.tri-mag.com
FAX: (559)651-0188

TITLE: SMPS GLOSSARY

APPLICATION NOTE
TMI-AN 08-005 Rev. A

U

U.L.

Underwriters Laboratories Incorporated. An independent, non-profit U.S. organization that tests products for safety.

UNDERSHOOT

A transient change in output voltage, below output accuracy limits, which can occur when a power supply is turned on or off, or when there is a step change in line or load. [See Figure 8.](#)

UPS

Uninterruptible Power Supply. A power supply which continues to supply power during a loss of AC input power. This is accomplished by means of a back-up battery and a DC/AC inverter or DC/DC converter.

V

VDE

Verband Deutscher Elektrotechniker. A German organization which tests equipment for public safety and emitted noise.

VOLTAGE BALANCE

The difference in magnitude, in percent, between the two output voltages of a dual output power supply where the voltages have equal nominal values with opposite polarities.

W

WARM-UP DRIFT

The initial change in output voltage of a power supply from turn-on until it reaches thermal equilibrium at nominal line, full load, 25C ambient temperature.

WARM-UP TIME

The time required, after initial turn-on, for a power supply to meet its performance specifications.

X

No terms listed.

Y

No terms listed.

Z

No terms listed.

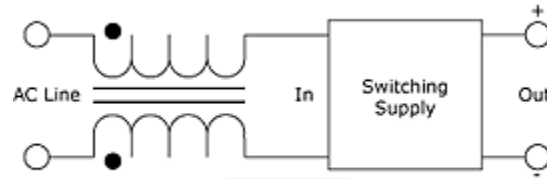

Figure 1

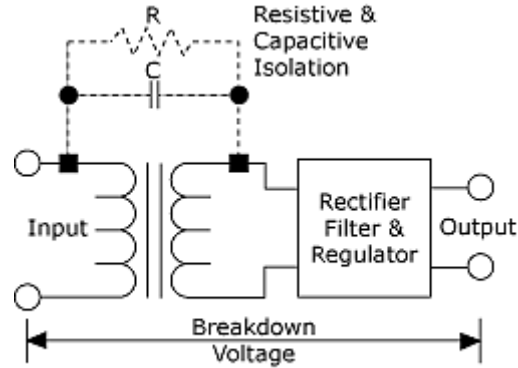

Figure 2

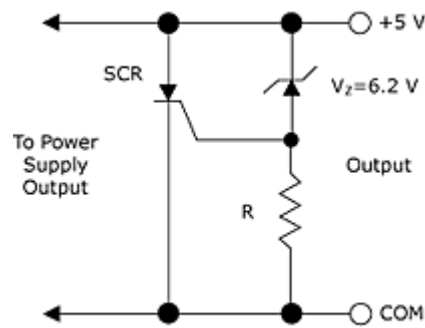

Figure 3

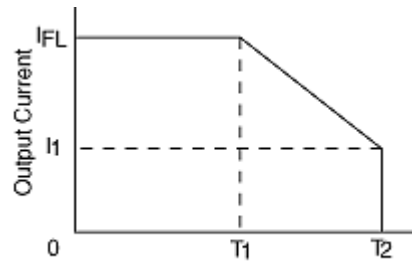

Figure 4

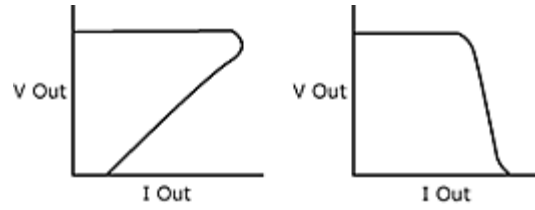

Figure 7

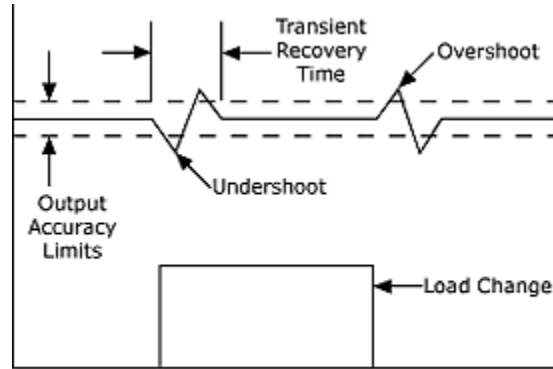

Figure 8

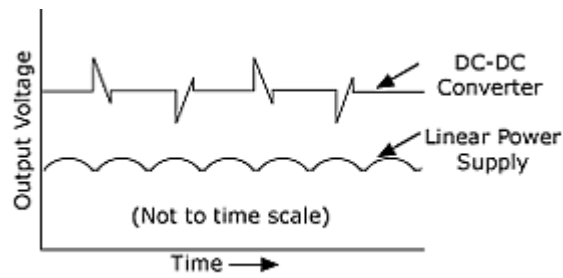

Figure 9

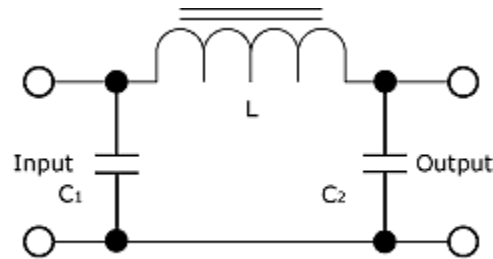

Figure 10

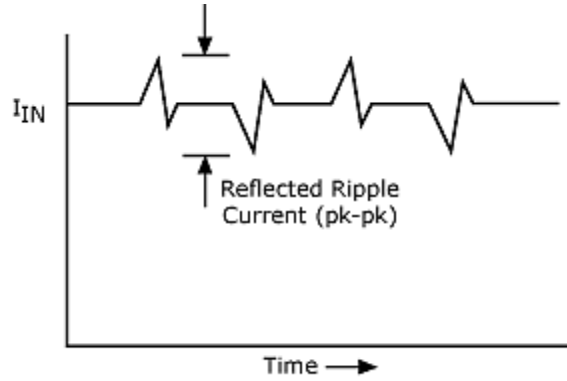

Figure 11

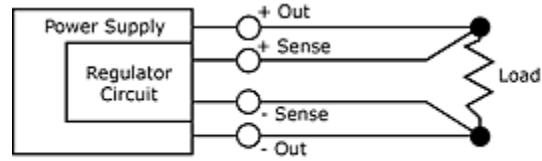

Figure 12